



[pro]master®

170SL [*Speedlight*]

TTL Speedlight for Nikon



Contents

Foreword	2
Precautions	3
Parts Identification	4
LCD Panel	6
Basic Operation	7
Flash Modes	13
I-TTL Mode	13
Manual Mode	14
RPT Repeat (Stroboscopic) Mode	15
Wireless Modes	17
Master Mode	17
Slave Mode	19
Advanced Applications	21
Power Zoom Function	21
FEB Flash Exposure Bracketing	22
FV Flash Value Lock	23
Front / Rear Curtain Sync.	24
Bounce Flash Operation	25
Bounce Card	26
Wide Panel	27
Advanced Wireless Flash	28
Troubleshooting Guide	29
Specifications	31
Appendix	32

Foreword

Thank you for purchasing the [pro]master 170SL.

The **ProMaster** 170SL is a high performance CLS compatible flash unit with a guide number of 52 m/170 ft (ISO 100 at the 180mm zoom position). The 170SL works with your camera as a I-TTL auto flash or as a manual control unit. It can serve as an on-camera flash as well as a master unit or a slave unit in a wireless, multiple-speedlight system.

Here are some of the 170SL's features:

- High Guide number: 52
- Low Recycle time: 4.5 seconds (AA alkaline) or 2.5 seconds (AA NiMH rechargeable)
- 22 Levels of light output control
- Compatible with Nikon wireless, optical flash system (can be used as master or slave)
- Compatible with I-TTL autoflash system
- Power zoom function matches your lens focal length
- Support front-curtain/rear-curtain sync
- Thermal cut-off protection to prevent overheating

To get the most out of your speedlight, please read this manual thoroughly before use.

Included items

Your 170SL comes with the following accessories.

- Soft Storage Case
- Speedlight Mini Stand
- User's manual

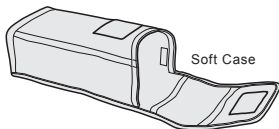
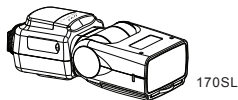

Precautions

1. Do not disassemble, open, or repair this speedlight by yourself.
2. Always use batteries of the same type, brand, and age. Always replace all 4 batteries at the same time. Do not combine different types, brands, old, or new batteries. This could cause the batteries to overheat, leak, or explode.
3. This product is not water-resistant. Keep it away from rain, snow, and high humidity areas.
4. Install the batteries in the proper orientation as indicated in the battery chamber. Installing the batteries incorrectly could cause them to overheat, leak, or explode.
5. If you change the batteries after a period of sustained continuous firing of the speedlight, the batteries may become warm or hot. This is normal, however you should be careful when handling these batteries.
6. Always switch the speedlight off before changing batteries.
7. Do not fire the speedlight from a short distance directly into the eyes of people or animals. This can cause damage to the retina and may even lead to blindness.
8. Avoid corrosive or flammable substances when cleaning this speedlight.
9. To prevent overheating and damage to the flash head, do not fire more than 25 continuous flashes in rapid sequence at full power (1/1 level). In this case the overheating mode will be activated and the flash will shut down. Allow it to return to normal operating temperature before using. This takes about 15 minutes.
10. Do not touch the speedlight with wet hands. This could cause an electrical shock.
11. Remove batteries from the unit before storing.

Parts Identification

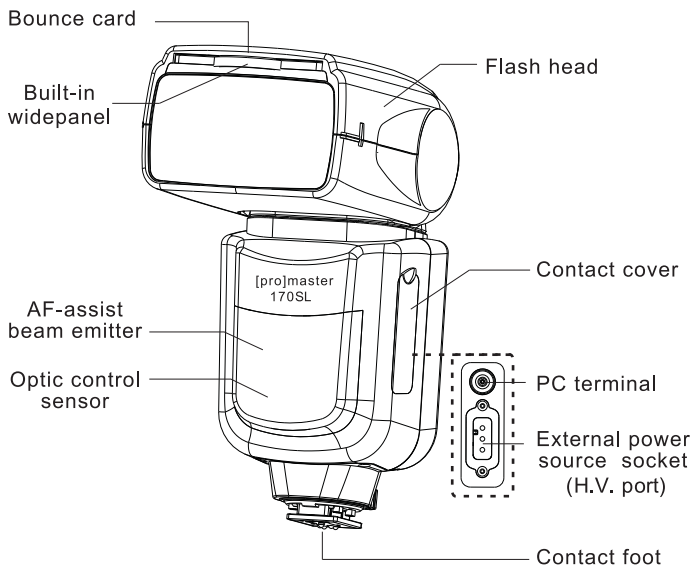

Parts Identification

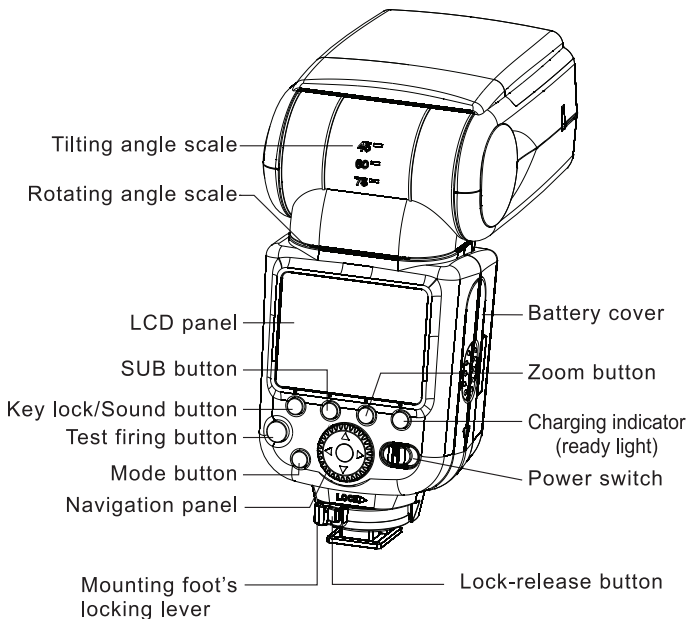

LCD Panel Icons

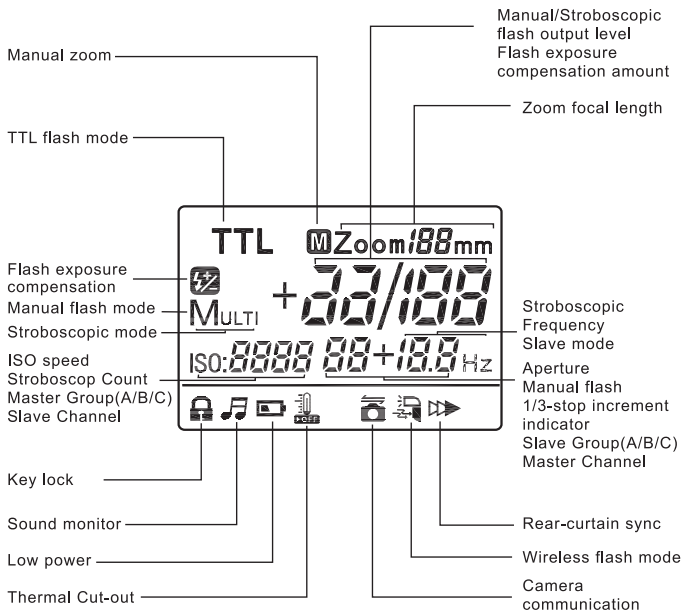

Basic Operation

Inserting The Batteries

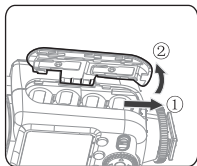

1 Open the cover.

Slide cover in the direction of the arrow and flip open.

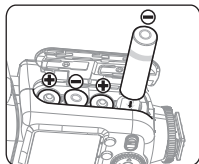

2 Install the batteries.

Make sure the + and - battery contacts are properly oriented as shown inside the battery compartment.

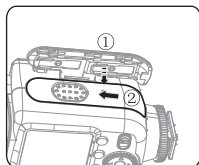

3 Close the cover.

Close the battery compartment cover by flipping it down, pressing and sliding it closed.

- Only use size AA alkaline or Ni-MH batteries.
- If you change the batteries after firing many continuous flashes be aware that the batteries might be hot.
- Before changing the batteries, be sure to turn off the speedlight.

Basic Operation

Attaching and Detaching the Speedlight

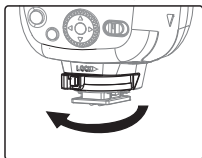

1 Prepare to attach the Speedlight.

Slide the lock lever to the left. If the lever is in the locked position (to the right) push the button to release it before sliding left.

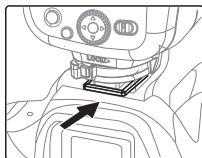

2 Attaching the Speedlight.

Mount the Speedlight into the camera's hot shoe all the way.

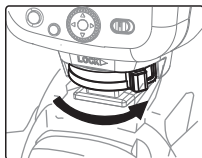

3 Securing the Speedlight.

On the mounting foot, slide the lock lever to the right until it locks in place.

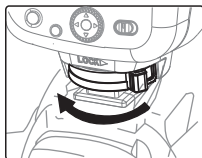

4 Detaching the Speedlight.

While pressing the lock-release button, slide the lock lever to the left and detach the speedlight by sliding it out of the camera's shoe.

- Before attaching or detaching the speedlight, be sure to turn off the speedlight.

Basic Operation

Turning on the power

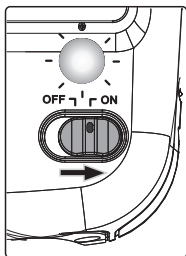

① Turn on the power.

Slide the power switch to <ON>. The charging indicator light will begin as red, then change to green after a few seconds, and you will hear two beeps. The speedlight is now ready.

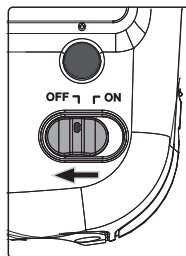

② Turning off the power.

Slide the power switch to <OFF>.

- If the charging indicator remains red, and <  > is displayed, please replace the batteries with new ones.
- In order to conserve power, the speedlight will enter sleep mode after 3 minutes of no use. In sleep mode, the LCD will go blank. You can press the shutter button halfway or press the test fire button to wake it up.
- The 170SL will NOT enter sleep while in Slave Mode.

Basic Operation

Charging Indicator and LCD backlight

Status of Charging indicator	Speedlight condition	Operation
The red light is lit	Charging	Normal
The green light is lit	The 170SL is fully charged and ready for use	Normal
The red light is lit for a long time	Battery power is low	Replace the batteries

Supporting function

LCD Backlight

- When the 170SL is first switched <ON>, the LCD will be illuminated due to its backlight. After 15 seconds of non-use, the backlight will turn off but the LCD will remain on. Press any button and the LCD backlight will illuminate once more.

Basic Operation

Sound monitor

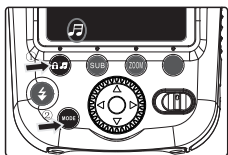

1 Enable Sound monitor.

Press button until the icon blinks. Then press the <MODE> button to confirm the setting. The icon will remain when sound is set to ON.

2 Disable Sound monitor.

Press the button until the icon blinks. Then press the <MODE> button to confirm the setting. The icon will disappear and sound is now set to OFF.

Sound monitor	Speedlight condition
One beep	A normal flash has just fired. Or, a button has been pressed during normal operation.
Two beeps	The 170SL is fully charged and ready to fire.
Short beeps for 15 seconds	Entering thermal protection mode to prevent the unit from overheating.

Keylock

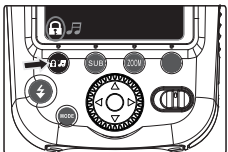

1 Enable Key Lock.

Press button until the icon blinks. Then press the <MODE> button to confirm. The icon will remain when key lock is ON.

2 Disable Key Lock.

With the key lock ON, hold the button for 2 seconds. When the icon disappears, all buttons can be used.

Basic Operation

Additional Interfaces

The 170SL has external connections for use of an external power source (High Voltage battery pack) or PC sync.

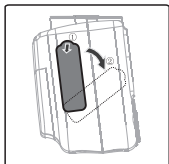

① Accessing the external power connector and PC sync.

Use the thumb tab to pull open the rubber cover on the side of the 170SL and rotate it out of the way.

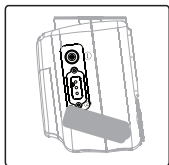

② Connecting.

- ① PC Sync: The Speedlight can fire in sync using this port.
- ② External power connector: The H.V. (high voltage) port provides a stable power supply.

- External power source: Use of an optional, external power source connected to the 170SL's H.V. port provides a stable power supply and increases the number of flash firings while shortening shot-to-shot recycling times.
- PC Sync: By connecting to the PC terminal you can fire the flash manually from a camera's PC socket (using the proper cord). The PC terminal ONLY fires the flash and does not support TTL or any other automatic, or exposure features.

Temperature monitor

The 170SL features thermal cut-out, which protects the unit against overheating.

- If the temperature of the unit becomes too high, this icon  will appear in the LCD screen. You will hear short beeps for 15 seconds as the unit locks-up for thermal protection. Please turn off the speedlight for 10 minutes until it cools down.
- The 170SL will automatically enter thermal protection mode when 25 flashes at 1/1 level (full power) are fired in quick succession.

Flash Modes

I-TTL Mode

In this mode information obtained by monitor pre-flashes and exposure control information are combined in-camera to automatically adjust flash output levels.

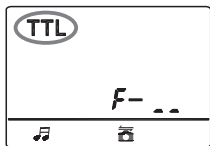

① Setting the 170SL to <I-TTL> mode.

Press the <MODE> button until <TTL> appears on the LCD. The default flash exposure compensation is 0 until you change it.

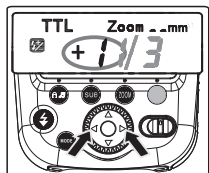

② Set the flash exposure compensation.

Press left/right arrows on the navigation panel to decrease/increase the flash exposure compensation by whole EV stops.

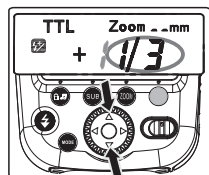

③ Fine tuning the flash exposure compensation.

Press up/down arrows on the navigation panel to decrease/increase the flash exposure compensation by 1/3 EV stops.

- When using with a Nikon camera and fully compatible lens, the 170SL's exposure and focal length are automatically set to match the camera settings unless you change them.

Flash Modes

Manual Mode

You can set the speedlight to manual mode and choose a power level between 1/1 and 1/128.

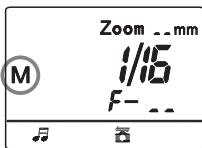

1 Set the speedlight to < M > mode.

Press the <MODE> button until <M> appears on the LCD screen. The 170SL is now in Manual mode.

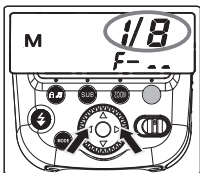

2 Set the flash power.

Press left/right arrows on the navigation panel to decrease/increase the flash output level by whole EV stops.

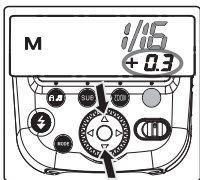

3 Fine tuning the flash power.

Press up/down arrows on the navigation panel to decrease/increase the flash output level by 1/3 EV stops.

Flash Modes

Repeat (Stroboscopic) Mode

In Repeat mode, the 170SL fires repeatedly during a single exposure, creating stroboscopic multiple-exposure effects. This operation is useful when shooting fast moving subjects .

You can set the firing frequency (number of flashes per second expressed as Hz), the number of flashes, and the flash output.

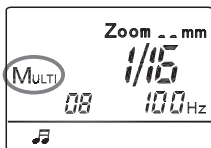

1 Set the speedlight to <MULTI>.

Press the <MODE> button until <Multi> appears on the LCD panel.

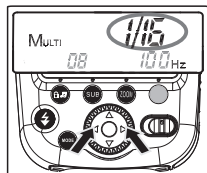

2 Set the flash output level.

Press left/right arrows on the navigation panel to decrease/increase the flash output level.

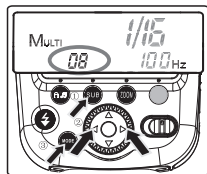

3 Set the number of flashes (times).

- 1 Press the <SUB> button and the number will blink.
- 2 Press left/right arrows on the navigation panel to decrease/increase the number one at a time. Or the up/down navigation can change the number to its max/min.
- 3 Press the <MODE> button to confirm the settings.

Flash Modes

Repeat (Stroboscopic) Mode

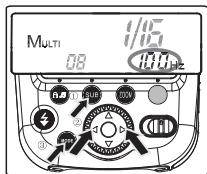

4 Set the firing frequency.

- ① Press the <SUB> button twice and the Hz number will blink.
- ② Press left/right arrows on the navigation panel to decrease/increase the number one at a time. Or the up/down navigation can change the number to its max/min.
- ③ Press the <MODE> button to confirm the settings.

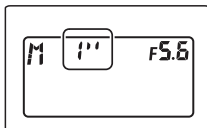

5 Set the shutter speed.

- Use the following equation to determine the shutter speed. Then set your camera to a shutter speed slower than the calculated number.
$$\text{Shutter speed} = \text{Number of flashes per frame} / \text{Frequency of flash (Hz)}$$
- For example, if the number of flashes per frame is 10 and the frequency is 5Hz, divide 10 by 5 to get a shutter speed of 2 seconds or slower. (set a shutter speed of slower than 2 seconds.)
- B(bulb) can be used for the shutter speed.

- Using a tripod, a remote switch, and external power source is recommended.
- To avoid overheating and deteriorating the flash head, don't use stroboscopic flash more than 10 times in succession. After 10 times, allow the speedlight to rest for at least 15 minutes.
- The maximum flash firing number is a function of flash output level and frequency. See the appendix for more details.

Wireless Modes

Master Mode

The 170SL can be used as the master unit in the Nikon CLS system. In this mode, you can divide the slave units into three groups and set the flash mode and flash output level compensation values separately for each group as well as the master flash unit.

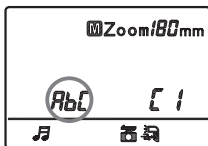

1 Press the <MODE> button to choose master mode.

Press the <MODE> button numerous times (if necessary) until the <AbC> icons appears on the LCD display.

<AbC> icons correspond to A.B.C firing groups.

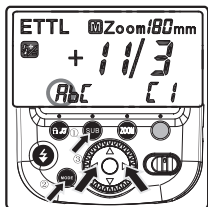

2 Set the flash mode for each group.

- 1 Press the <SUB> button so group A or B or C blinks.
- 2 Press the <MODE> button to choose a flash mode for that group. Choose TTL, M, or remove the group (flash cancelled).
- 3 Press the navigation arrows to choose a compensation value for the group.

- The following three flash modes are available:
i-TTL mode, Manual mode, Flash canceled.
- In flash canceled mode, the group will be closed to avoid unnecessary interference.

* Example: Below shows group B in flash canceled mode.

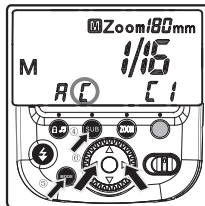

- 4 Press the <SUB> button to select another group.
- 5 Press the <MODE> button to choose the flash mode for that group.
- 6 Press the navigation arrows to choose a compensation value for the group.

- For more information about setting compensation values see page P14.

Wireless Modes

Master Mode

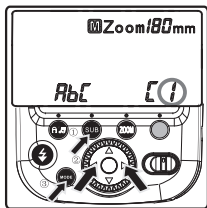

3 Set the channel.

- 1 Press the <SUB> button until the channel number blinks.
- 2 Press the left/right navigation arrows to decrease/increase the channel number.
- 3 Press the <MODE> button to confirm.

As you press the <SUB> button over and over the 170SL will cycle through each of the 3 groups and then the channel.

- Select a channel number between 1 and 4.

- If another photographer is using the same type of wireless flash setup nearby, your slave flash units may accidentally fire in-sync with that photographer's master flash unit. To avoid this, use a different channel number.
- The 170SL can control Nikon SB-600/700/800/900/910, ProMaster 100SL, 200SL and other Nikon optical wireless CLS flashes.
- The 170SL does not support high-speed wireless flash. Don't set the shutter speed to 1/200 or more.
- The 170SL does not support Repeating flash mode (RPT) in wireless.
- For the master unit you can use the wide panel to effectively widen the transmission from the master to the slave units.

Wireless Modes

Slave Mode

As a slave unit, the 170SL can receive signals from another 170SL, ProMaster 100SL, ProMaster 200SL, Nikon SB-600/700/800/900/910 and other Nikon wireless flash system compatible items (optical, non-radio). In this mode, you can divide the slave units into three groups and set the flash mode and flash output level compensation values separately for each group as well as the master flash unit.

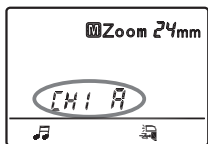

- 1 Press and hold the <MODE> button for 2 seconds to choose slave mode.**

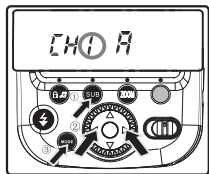

- 2 Set the channel.**

- 1 Press the <SUB> button until the channel number blinks.
- 2 Press left/right navigation arrows to decrease/increase the channel number.
- 3 Press the <MODE> button to confirm the setting.

- Select a channel number between 1 and 4.

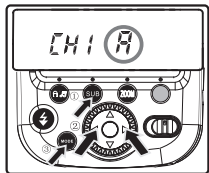

- 3 Set the group.**

- 1 Press the <SUB> button until the group number blinks.
- 2 Press left/right navigation arrows to decrease/increase the group number.
- 3 Press the <MODE> button to confirm the setting.

- Select a group number of A, B, or C.

- The 170SL is compatible with Nikon TTL and M wireless flash, without support for auto aperture flash and repeating flash modes.
- The 170SL doesn't support high-speed wireless flash. Don't set the shutter to 1/200 or higher.
- You can use the camera's built-in flash as a master flash unit to trigger the slave unit(s), if available. Be sure to raise the built-in flash.

Wireless Modes

Ready Light and Parameter Display

Ready Light

- When the 170SL is in slave mode, the front (red) panel of the unit near the Optic Control Sensor will blink.

Parameter Display

- When a 170SL in slave mode receives a signal from the master, it will briefly display the Mode used by the master on its LCD as TTL or M.

For example

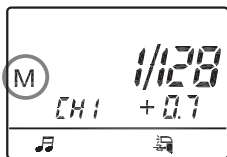

If the slave receives a manual wireless flash signal from the master, the icon <M> and the master's parameters will appear on the LCD of the slave for a few seconds, after it fires.

- Fine tuning information will appear in the group area of the slave's LCD.
Display time approximately 3 seconds.

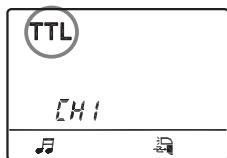

If the slave receives TTL wireless flash signals from the master, the icon <TTL> will appear on the LCD of the slave for a few seconds, after it fires.

Advanced Applications

Power Zoom Function

The power zoom function automatically adjusts the flash zoom head position to match the lens focal length. Zoom positions can be adjusted between 24mm and 180mm. You can also adjust the flash zoom head position manually.

Auto zoom

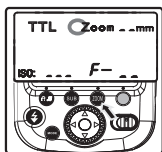

Press the <ZOOM> button, then press the left navigation arrow until <M> disappears from the LCD. Two blinking lines will be shown next to 'mm'. Now press the <ZOOM> button to confirm the setting. With the camera turned ON, zoom the lens and watch the numbers next to 'mm' change with the lens focal length.

Manual zoom

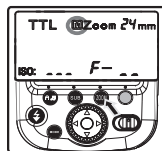

Press the <ZOOM> button, then press the left/right navigation arrows to decrease/increase the value (shown in mm). An <M> symbol will be shown to the left of 'Zoom' on the LCD to indicate manual zoom mode. Pressing the up navigation arrow will change the zoom position directly to 180mm. Pressing the down navigation arrow will change directly to auto zoom mode.

- If you set the flash zoom manually, make sure it covers the lens focal length so that the picture will not have a dark periphery (the appearance of vignetting on the edges of the photo).
- If you are using a sync cord to connect the camera to the speedlight's PC terminal, be sure to set the flash zoom manually since the auto zoom function will not work.

Advanced Applications

FEB Flash Exposure Bracketing

1 Choose the number of shots.

Press the BKT button on the camera and rotate the main command dial to choose the number of shots in the bracketing sequence.

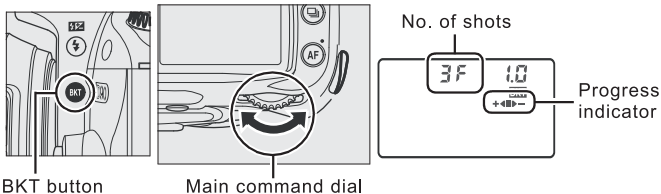

2 Select an exposure increment.

Press the BKT button and rotate the sub-command dial to choose the exposure increment from values between 0.3EV and 2.0EV.

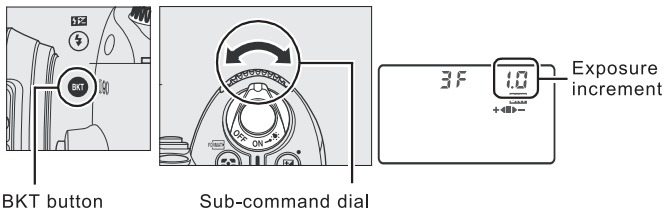

- To cancel bracketing, press the BKT button and rotate the main command dial until the number of shots in the bracketing sequence is 0.
- Not all cameras may work the same with the BKT function. These instructions are meant to demonstrate a somewhat common method. Refer to your camera's instruction manual for more specific details about its BKT function.

Advanced Applications

FV Flash Value Lock

Using FV Lock you can lock in the appropriate flash exposure for your subject and then recompose the shot.

Metering method button

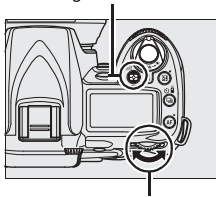

Main command dial

Shutter-release button

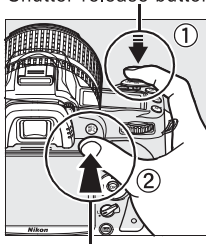

AE-L/AF-L button

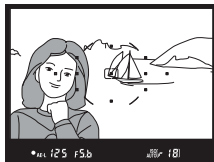

- 1 Select mode P, S, or A and choose center-weighted or spot metering on your camera.**
- 2 Focus on the subject, and press the AE-L/AF-L button on the camera.**
- 3 Keeping the AE-L/AF-L button pressed, recompose the photograph and shoot.**

* Note, the FV Lock controls and method might be different for your specific camera. Refer to your camera's instruction manual for more details.

Advanced Applications

Front-curtain/Rear-curtain sync

Using front-curtain sync, the speedlight will fire immediately after the front curtain opens completely.

Using rear-curtain sync, the flash fires just before the rear curtain starts to close.

When shooting a fast-moving subject at slow shutter speeds, rear curtain sync creates a more natural looking photograph with a blur shown behind the subject.

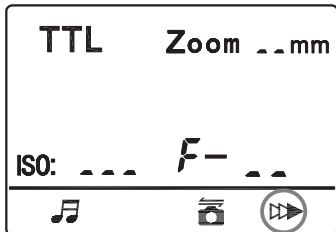

When you select rear-curtain sync from the camera the <⏏> icon will appear on the 170SL's LCD screen.

Advanced Applications

AF assist beam emitter

In low light conditions the AF assist light will automatically emit a red colored beam and illuminate the subject so the camera can easily focus.

Bounce flash operation

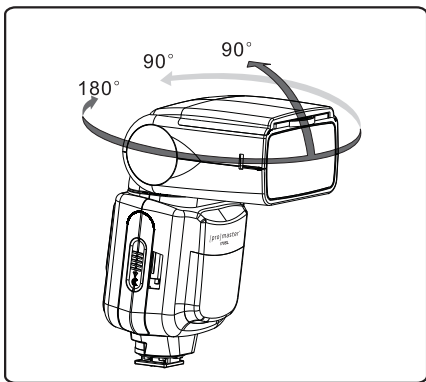

Tilt or rotate the 170SL's flash head to bounce the light off a ceiling or wall, providing more natural-looking pictures of people with softer shadows.

- If the wall or ceiling is too far away, the bounced flash might be too weak and result in underexposure.
- Be sure to select a white/neutral surface to bounce the light off of. Otherwise your pictures will have an unnatural looking color cast similar to that of the reflecting surface.

Advanced Applications

Using the Bounce Card

You can use the 170SL's built-in bounce card to create a highlight in the subject's eyes, soften the light output, and reduce the chance of red-eye (by creating more distance between the light and the lens).

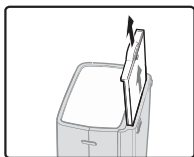
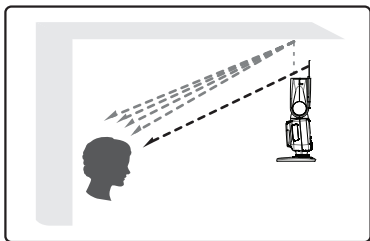

1 Point the flash head upward by 90°.

2 Pull out the wide panel.

The bounce card panel will come out at the same time.

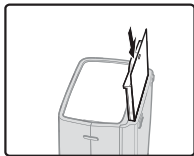

3 Push the wide panel back in.

Push in only the wide panel. Leave the bounce card out.

- Point the flash head straight ahead and then upward by 90°. The bounce card will not work properly if you swing the flash head left or right.
- For maximum effect, stay within 1.5m(4.9ft) of the subject.

Advanced Applications

Using the Wide Panel

When the distance between the camera and subject is less than approximately 2m(6 1/2 ft), you can take more natural-looking close-up pictures using the wide panel.

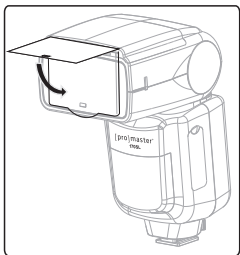

1 Pull out the wide panel.

Slowly pull out the wide panel all the way, and position it over the flash head.

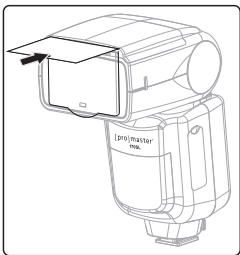

2 Push the bounce card back in.

- The wide panel is most effective when the 170SL's zoom head reflector is set to its widest-angle position. To accomplish this you can either set your zoom lens to its widest position while the 170SL is in auto zoom mode, or you can switch to manual zoom mode and change the 170SL's zoom position to its widest setting.

Advanced Applications

Advanced Wireless Flash

The 170SL supports multiple wireless flash setups using an optical-wireless communication system.

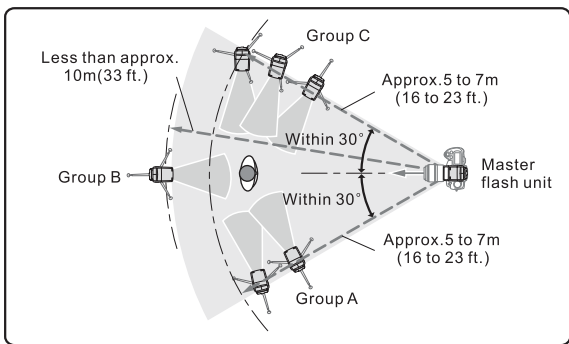

- The 170SL supports Nikon's CLS system (wireless optical, non-RT).
- The 170SL can be used as a master or slave flash.
- Be sure to test the wireless flash operation before shooting.
- When used as a slave, confirm the unit(s) can receive a good optical signal. See the diagram above for optimal setup.
- As a basic guide, the effective shooting distance between the master and slave units is approx. 10m (33 ft.) or less in the front position, and approx. 7m (23 ft.) at the sides. These ranges vary slightly depending on the ambient light.
- Indoors, the wireless signal can also bounce off the wall, so there is more leeway in positioning the slave units.
- Try to place all slave units that are set in the same group close together.
- Don't place any obstacles between the master unit and slave units. Obstacles can block the transmission of wireless signals.

Troubleshooting Guide

■ The Speedlight Does Not Fire

Possible Cause: The batteries are installed in the wrong orientation.

Solution: Install the batteries in the correct orientation.

Possible Cause: The batteries are exhausted.

Solution: Replace the batteries.

Possible Cause: The Speedlight is not attached securely to the camera.



Solution: Attach the Speedlight's mounting foot securely to the camera.

Possible Cause: The electrical contacts of the Speedlight and camera are dirty.

Solution: Clean the contacts.

■ Test Fire Button Does Not Respond

Possible Cause: Control buttons are locked.

Solution: Look at the LCD display, if the <  > icon appears, please press the <  > button to close it. Refer to page 11 for more information.

The Slave Unit Does Not Fire

Possible Cause: The slave's mode is set wrong.

Solution: Please set it to same wireless mode, group, and channel as the master unit.

Possible Cause: The slave unit(s) is not positioned properly.

Solution: Place the slave unit within the master unit's transmission range.

Exposure Seems Incorrect

Symptom: Photos are under exposed or over exposed.

Solutions: Check the 170SL to see if exposure compensation has been changed. Also check your camera's mode and settings.

Symptom: The periphery or bottom of the picture looks dark.

Solution: If the subject is closer than 2 m (6 1/2 ft), tilt the flash head downward by 70°.

Specifications

Type:	On-camera, I-TTL autoflash speedlight
Guide No. :	GN 52m / 170' (at 180mm focal length, ISO 100)
Flash coverage:	24-180mm Auto zoom (Flash coverage set automatically to match the lens focal length) Manual zoom
Wireless mode:	Nikon wireless flash mode (master & slave modes)[optical, non-RT system]
Audible:	Electronic Beep (ON or OFF)
Display type:	LCD display with LED backlit
Protection type:	Thermal Cut-out
Power supply:	4 X AA size batteries (Alkaline or NiMH cells)
Flash duration:	1/800 - 1/20000 second
Recycle time:	0.2 - 4.5 seconds (AA alkaline cell use) 0.1 - 2.5 seconds (AA NiMH cell use)
Color temperature:	5600K
Flash control :	22 Levels of light output control (1/1 ~1/128, 14 levels of fine tuning); I-TTL autoflash; Multi flash(RPT)
Power saving :	Auto power off after 3 minutes in stand-by mode
Vertical angle adjustment:	-7°~90°
Rotation adjustment :	90°Left ~180°Right
Dimensions:	7 3/4" x 3 1/16" x 2 5/16" (196.8mm x 77.8mm x 58.7mm)
Net weight :	14 oz / 396 g (without batteries)

Appendix

Guide No. (at ISO 100, in meters)

Flash output level	Zoom position(mm)									
	24	28	35	50	70	85	105	120	135	180
1/1	25.4	27.9	31.4	35.8	39.3	41.5	44.4	46.9	48.4	52
1/2	18.0	19.7	22.2	25.3	27.8	29.3	31.4	33.2	34.2	35.4
1/4	12.7	14.0	15.7	17.9	19.7	20.8	22.2	23.5	24.2	25
1/8	9.0	9.9	11.1	12.7	13.9	14.7	15.7	16.6	17.1	17.7
1/16	6.4	7.0	7.9	9.0	9.9	10.4	11.1	11.8	12.1	12.5
1/32	4.5	5.0	5.6	6.4	7.0	7.4	7.9	8.3	8.6	8.9
1/64	3.2	3.5	4.0	4.5	5.0	5.2	5.6	5.9	6.1	6.3
1/128	2.3	2.5	2.8	3.2	3.5	3.7	4.0	4.2	4.3	4.5

Appendix

Referring to the table below, set the flash output level, the frequency, and the number of repeating flashes separately for each picture.

Maximum number of repeating flash per frame

Frequency	Flash output level				
	M1/8	M1/16	M1/32	M1/64	M1/128
1Hz	14	30	60	90	90
2Hz					
3Hz	14	30	60	90	90
4Hz	12	20	50	80	80
5Hz	10	20	40	70	70
6Hz	8	20	32	56	56
7Hz	6	20	28	44	44
8Hz	6	20	24	36	36
9Hz	5	10	22	32	32
10Hz	5	10	20	28	28
20Hz	4	8	12	24	24
30Hz					
40Hz					
50Hz					
60Hz					
70Hz					
80Hz					
90Hz					
100Hz					

One Year Unconditional Warranty

If for any reason, this ProMaster product fails within ONE YEAR of the date of purchase, return this product to your ProMaster dealer and it will be exchanged for you at no charge. ProMaster products are guaranteed for ONE FULL YEAR against defects in workmanship and materials. If at any time after one year, your ProMaster product fails under normal use, we invite you to return it to ProMaster for evaluation.

WWW.PROMASTER.COM | FAIRFIELD CT 06825

**FOR
NIKON**

Made in China

Code 2057

